

# General Assembly Instructions for V3 Cage Hinged Door

The following assembly installation instructions are for a single hinged cage door.

Specific layout information for door placement will be provided in addition to these instructions. Item numbers referenced in these instructions apply only to this parts list. Please refer to the parts list and drawings sent with your containment unit for actual layout and part numbers.

## Tools Required:

- 7/16" Socket or wrench
- 3/8" Socket or wrench
- #2 Phillips head screwdriver
- #2 Robertson head screwdriver

## Tips For Installation:

- Review all drawings and instructions first
- Unpackage items from the box and group accordingly. Ensure all parts are accounted for (refer to parts list of the accompanied layout drawings as reference)
  - Note: Some items may already be pre-assembled
- Ensure wall columns and panels are securely fastened and level prior to door install. Failure to do so may result in poor door function
- Check all measurements prior to install and after with a tape measure.

The information contained herewithin is proprietary and confidential to R.F.MOTE LTD. It may not be reproduced or further disseminated, in whole or in part, without prior written consent from R.F.MOTE LTD.

**R.F.MOTE**



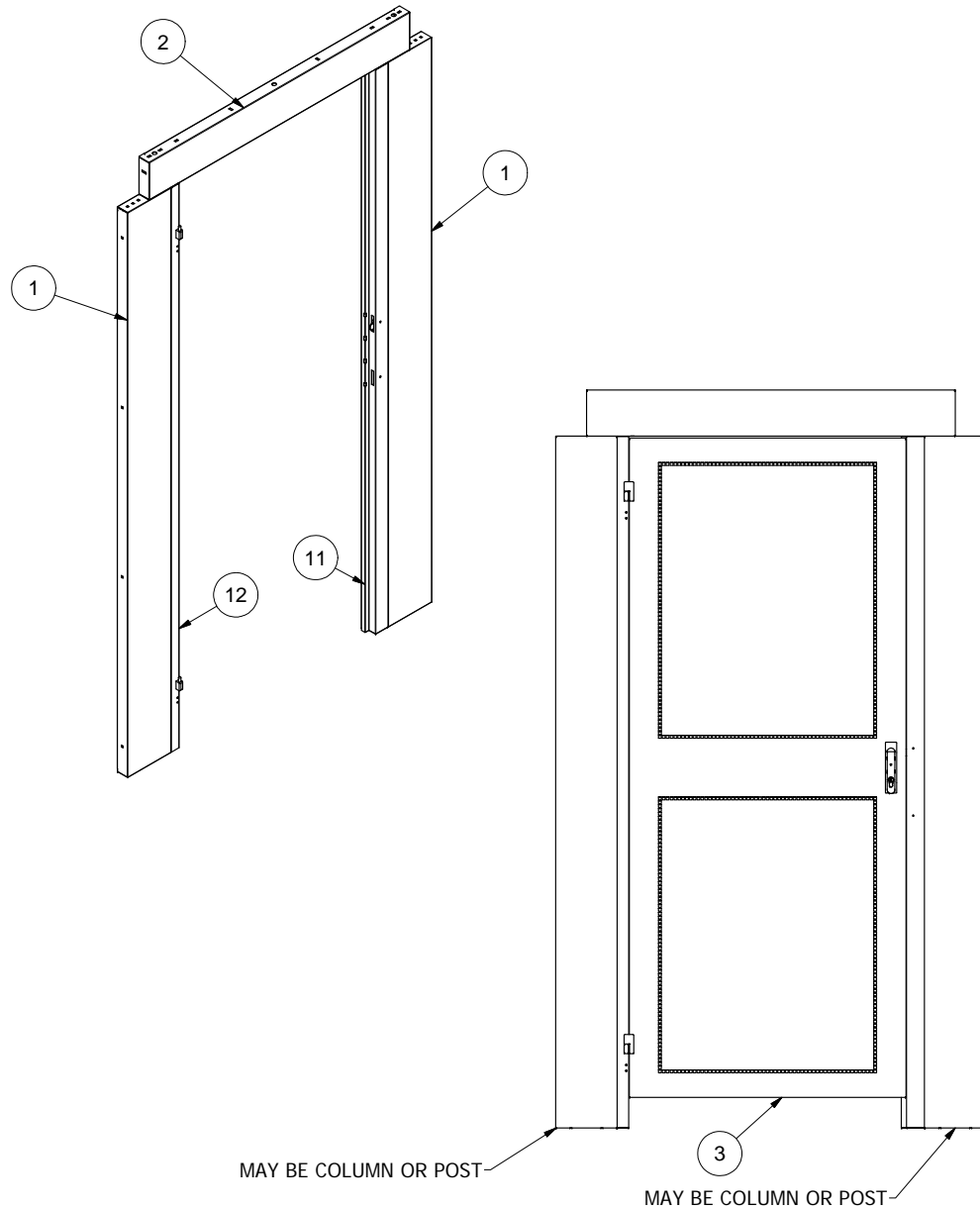

| PARTS LIST |     |                              |
|------------|-----|------------------------------|
| ITEM       | QTY | PART NUMBER                  |
| 1          | 2   | COLUMN OR CORNER             |
| 2          | 1   | RFM-CC-J-6-48                |
| 3          | 1   | RFM-CC-HD-3690-DOOR-LH-V3    |
| 4          | 1   | RFM-CC-HD-3690-V3-Lock Slide |
| 5          | 2   | 10-32 KEPS NUT               |
| 6          | 13  | 1/4-20 x 3/4 Carriage Bolt   |
| 7          | 13  | 1/4-20 Keps Nut              |
| 8          | 14  | 5/16 Flat Washer             |
| 9          | 2   | DOOR HINGE MALE              |
| 10         | 4   | 10-32 x 3/8 Pan Quad MS      |
| 11         | 1   | RFM-CC-HD-3690-V3-STOP       |
| 12         | 1   | RFM-CC-HD-3690-V3-POST       |
| 13         | 1   | E5-6608-Southco              |

**NOTE: Door Frame Assembly: ( Left Hand As Shown - Right Hand Opposite)**

1. Attach RFM-CC-HD-3690-V3-Stop (Item 11) to the right side column (Item 1) and the upper valance panel (Item 2) using 5 pcs of 1/4-20 x 3/4" carriage bolt (Item 6), 1/4-20 keps nuts (Item 7) and 5/16" flat washer (Item 8). Tighten using the 7/16" socket or wrench.
2. Attach RFM-CC-HD-3690-V3-Post (Item 12) to the left side column (Item 1) using 4 pcs of 1/4-20 x 3/4" carriage bolt (Item 6), 1/4-20 keps nuts (Item 7) and 5/16" flat washer (Item 8). Tighten using the 7/16" socket or wrench.
3. Fasten 2 pcs of Door Hinge Male (Item 9) to each upper set of holes in RFM-CC-HD-3690-V3-Post (Item 12) using provided #10-32 x 3/8 machine screw (Item 10). Tighten using #2 Robertson Screwdriver
4. Install RFM-CC-HD-3690-V3-Lock Slide (Item 4) onto the studs in RFM-CC-HD-3690-V3-Stop (Item 11) using #10-32 Keps Nut (Item 5). Install with the arm protruding through the upper slot in (Item 11) Tighten using 3/8" socket or wrench. This may be pre-installed at factory.
5. Install RFM-CC-HD-3690-V3-Door onto Door Hinge Male (Item 9).

**Door slab will be shipped pre-assembled from Factory as ordered in either RH or LH version.**

**R.F.MOTE LTD**  
ENGINEERED SYSTEMS

214 NEWKIRK RD.  
RICHMOND HILL, ONTARIO  
L4C 3G7  
PHONE (905) 884-5250  
FAX (905) 737-5188

|                                  |       |              |     |
|----------------------------------|-------|--------------|-----|
| PROJECT                          |       |              |     |
| PART NUMBER                      |       |              |     |
| <b>RFM-CC-HD-3690-LH-V3 ASSY</b> |       |              |     |
| DATE                             | SCALE | WEIGHT       | REV |
| 16-Apr-19                        | 1 / 8 | N/A          | 02  |
| AUTHOR                           |       | SHEET 2 OF 3 |     |
| Voula                            |       |              |     |

The information contained herewithin is proprietary and confidential to R.F.MOTE LTD. It may not be reproduced or further disseminated, in whole or in part, without prior written consent from R.F.MOTE LTD.

| PARTS LIST |     |                              |
|------------|-----|------------------------------|
| ITEM       | QTY | PART NUMBER                  |
| 4          | 1   | RFM-CC-HD-3690-V3-Lock Slide |
| 13         | 1   | E5-6608-Southco              |

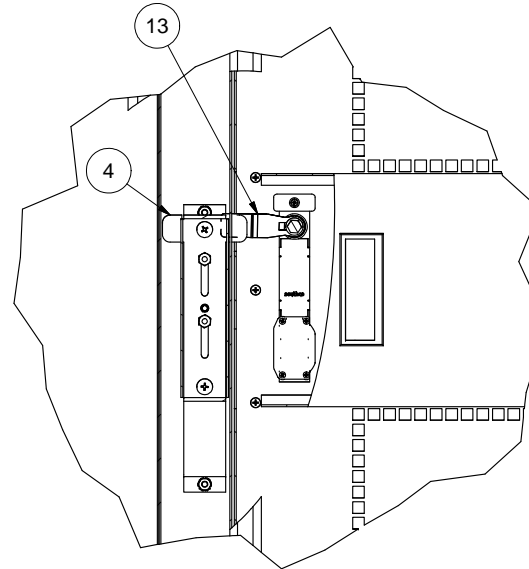
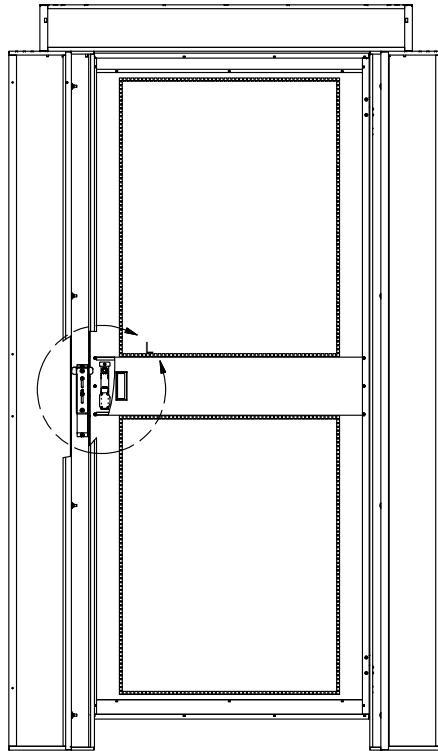

DETAIL L  
SCALE 1 / 2

**R.F.MOTE LTD**  
ENGINEERED SYSTEMS

214 NEWKIRK RD.  
RICHMOND HILL, ONTARIO  
L4C 3G7  
PHONE (905) 884-5250  
FAX (905) 737-5188

|                                  |       |              |     |
|----------------------------------|-------|--------------|-----|
| PROJECT                          |       |              |     |
| PART NUMBER                      |       |              |     |
| <b>RFM-CC-HD-3690-LH-V3 ASSY</b> |       |              |     |
| DATE                             | SCALE | WEIGHT       | REV |
|                                  | 1 / 8 | N/A          | 02  |
| AUTHOR<br>Voila                  |       | SHEET 3 OF 3 |     |

The information contained herewithin is proprietary and confidential to R.F.MOTE LTD.  
It may not be reproduced or further disseminated, in whole or in part, without prior written consent from R.F.MOTE LTD.