

ASSEMBLY INSTRUCTIONS: SWING-OUT RACK (44U & 38U) RFM-1944-RSO-ADJ / RFM-1938-RSO-ADJ

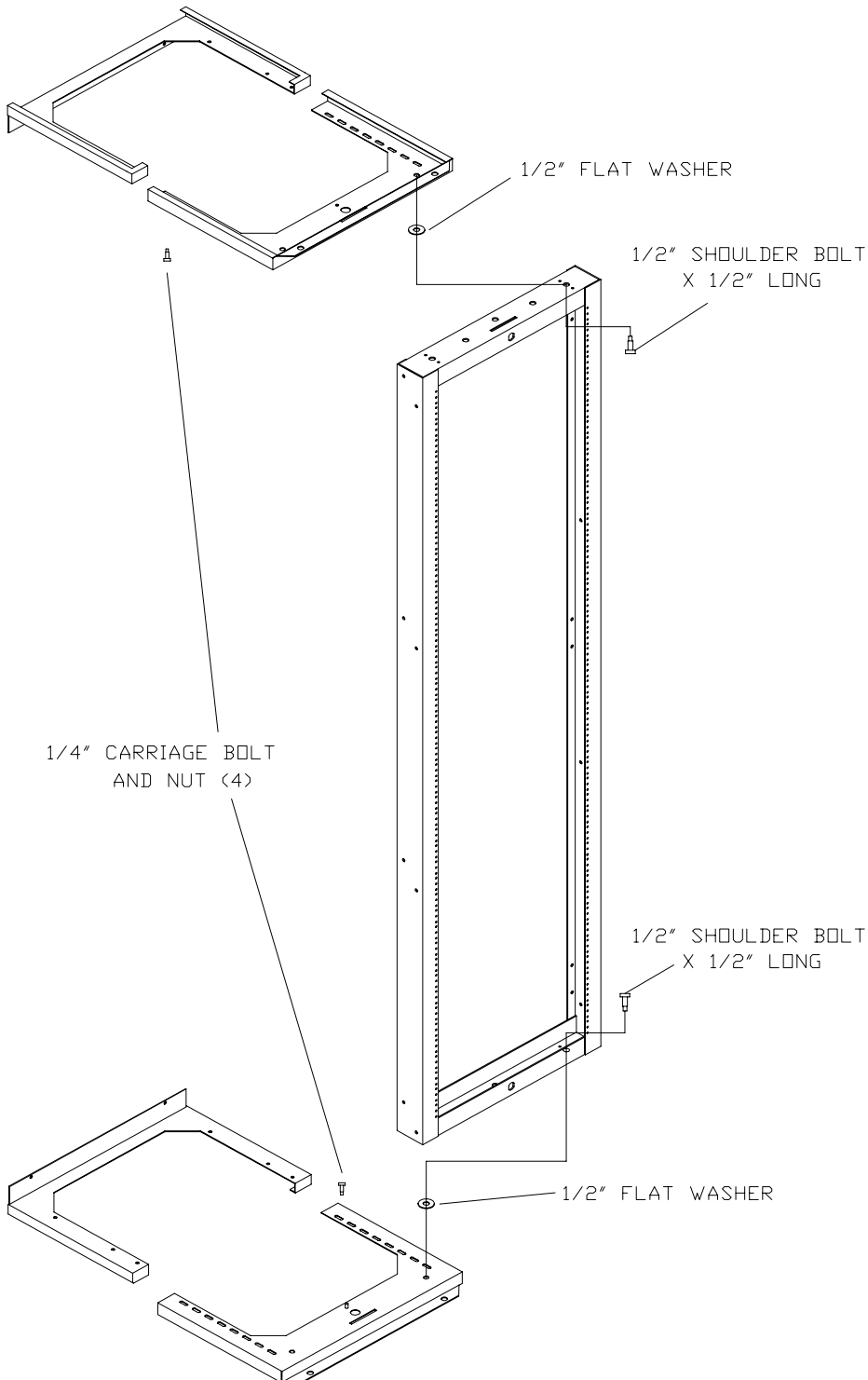

Step 1:
Determine rack position / location

Step 2:
Assemble top and bottom mounting brackets using supplied 1/4-20 X 3/4" carriage bolts and nuts. (see diagram)

Step 3:
Determine which way the rack will swing open. (diagram shows right hand side pivot point)

Step 4:
Attach mounting brackets to rack using 1/2" shoulder bolts (nut is welded to brackets) and flat washers.

note: be sure to place the washers between the rack frame and the bracket as this becomes the pivot point. (see diagram)

Step 5:
Lock rack in place using coin lock.

Step 6:
Stand the assembly vertically, position it with brackets facing the wall, with the bottom mounting brackets on levelled floor.

Step 7:
Securely fasten assembled rack unit to the wall.

Step 8:
Horizontal bracket adjustments (top or bottom) allow the unit to move closer to, or further away from, the wall. Loosen the 1/4" carriage bolts and slide the brackets in or out as required. Secure bracket bolts once desired position is determined.